

Silicon PIN Diode

BXY 42BA-7

- Fast switching

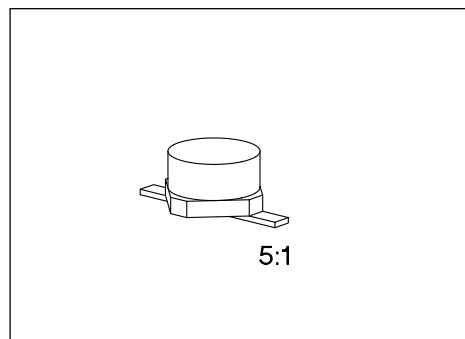

ESD: Electrostatic discharge sensitive device, observe handling precautions!

Type	Marking	Ordering Code	Pin Configuration	Package ¹⁾
BXY 42BA-7	27	Q62702-X160		Cerec-X

Maximum Ratings

Parameter	Symbol	Values	Unit
Reverse voltage	V_R	50	V
Peak forward current, $t_p = 1 \mu\text{s}$	I_{FRM}	5	A
Total power dissipation	P_{tot}	350	mW
Junction temperature	T_j	175	°C
Storage temperature range	T_{stg}	- 55 ... + 150	
Operating temperature range	T_{op}	- 55 ... + 150	

Thermal Resistance

Junction – ambient ²⁾	$R_{th JA}$	≤ 450	K/W
----------------------------------	-------------	-------	-----

1) For detailed information see chapter Package Outlines.

2) Package mounted on alumina 15 mm × 16.7 mm × 0.7 mm.

Electrical Characteristics

at $T_A = 25\text{ }^\circ\text{C}$, unless otherwise specified.

Parameter	Symbol	Values			Unit
		min.	typ.	max.	
Breakdown voltage $I_R = 10\text{ }\mu\text{A}$	$V_{(BR)}$	50	–	–	V
Reverse current $V_R = 40\text{ V}$	I_R	–	–	5	nA
Storage time $I_F = 10\text{ mA}$, $V_R = 10\text{ V}$	t_s	–	4	–	ns
Diode capacitance $V_R = 20\text{ V}$, $f = 1\text{ MHz}$	C_T	–	–	0.2	pF
Charge carrier life time $I_F = 10\text{ mA}$, $I_R = 6\text{ mA}$	τ_L	–	40	–	ns
Forward resistance $f = 100\text{ MHz}$, $I_F = 10\text{ mA}$	r_f	–	1.5	–	Ω